

RIKO Three Core Technologies

Six Key Points



PRC-320



PR-620

high quality, bending resistance
fiber optic sensor

Protection against excessive bending

- Special material for bending resistance (applying patent)

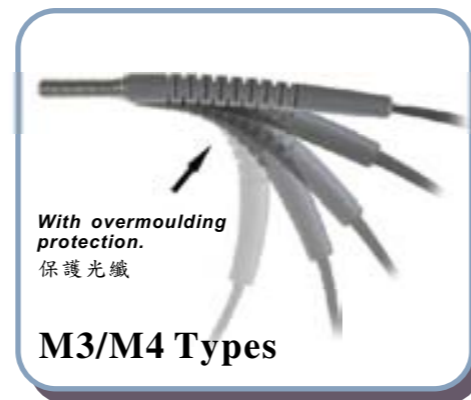
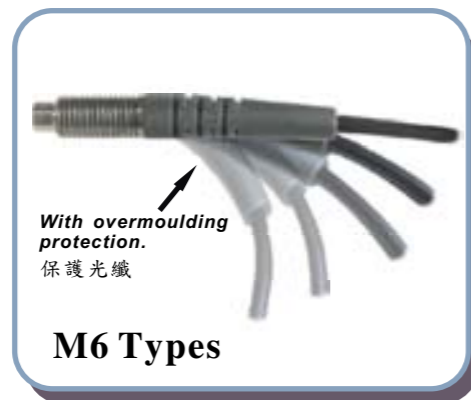

Traditional type fiber (less protection) will be damaged easily by smaller bending radius

special material for bending resistance : better curvature and protection from breakage of fiber in case of smaller bending radius in operation.

Swinging tests

Swings of PR series are not less than 10000. It will approve the durability.

High tensile strength

Tensile strength : 8kg

Tensile strength : 8kg is three times more stronger than traditional type fiber. It will keep fiber far from careless damage in operation.

High quality

Stainless steel fiber head (Shorter model)

- Stainless steel material.
- Much more durability.
- Shorter detector.
- Easy installation.

High quality fiber

- Superior fiber material from Japan.
- Lower attenuation.

Superior fiber polishing technology

RIKO's excellent polishing technology with great looking and higher quality

PR-620

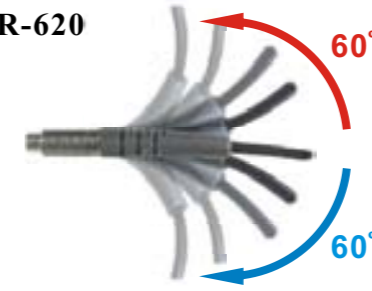

PRC-420/320

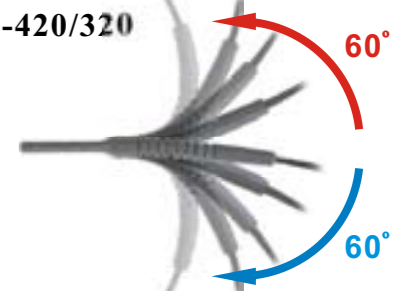

Swings of PR620 : 10000 and PRC-320/420 are up to 30000. It will efficiently protect the fiber and extend its service life.

Standard of test : swinging from left to right total 10 cm, 120 degree, speed : 12 seconds per swing

PR-620



Tensile strength : 8kg

PRC-420/320



Tensile strength : 7kg

PR-620

PR series

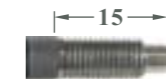

PRC-420



PRC-320



Traditional types

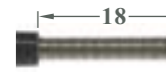

The length reduce approx. **35%**

23%

36%

PR-620

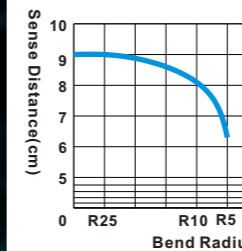

PRC-620

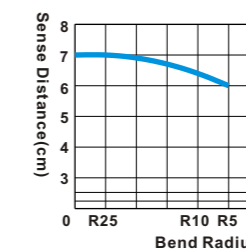

PRC-420/320

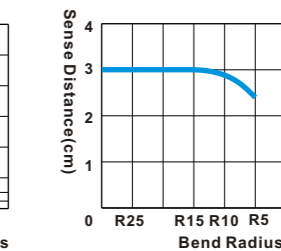

PRD-420/320

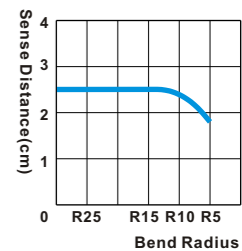

PR-620



PRC-620

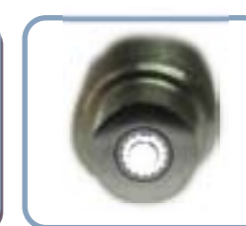

PRC-420/320

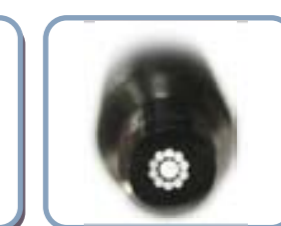

PRD-420/320

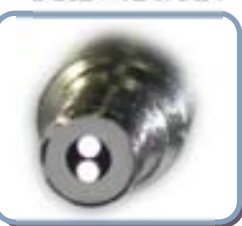

Fiber manufactured parallel, with great focusing but non-direction for installation. A faster and stable sensing while use our fiber sensor.



PR-620



PRC-620



PRC-420



PRD-420



PRC-320



PRD-320

Dimensions

Specifications

Dimensions

Specifications

PR-620

Free cut

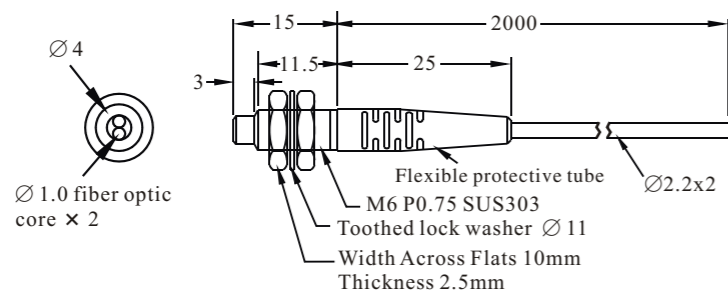

Fiber material	Plastic
Fiber Type	Standard
Fiber diameter	D \varnothing 2.2mm d \varnothing 1.0mm
Operate temperature	-55°C ~ +70°C
Minimum bending radius	R25
Sensing distance/FZ1-N	90mm

PRC-620

Free cut

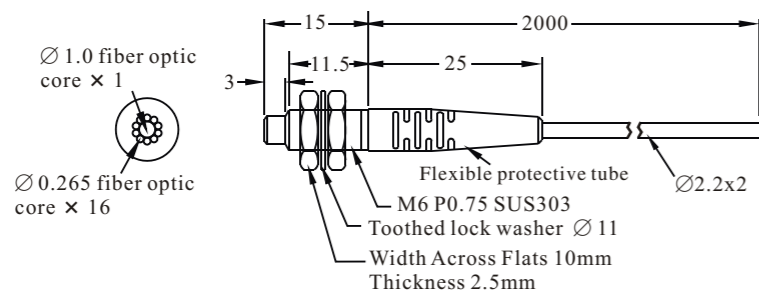

Fiber material	Plastic
Fiber Type	Coaxial
Fiber diameter	D \varnothing 2.2mm x1 \varnothing 2.2mm x1 d \varnothing 1.0mm x1 \varnothing 0.25mm x16
Operate temperature	-55°C ~ +70°C
Minimum bending radius	R25
Sensing distance/FZ1-N	70mm

PRC-420

Free cut

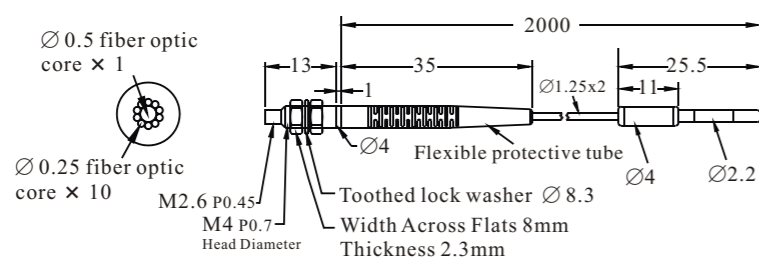

Fiber material	Plastic
Fiber Type	Coaxial
Fiber diameter	D \varnothing 1.25mm x1 \varnothing 1.25mm x1 d \varnothing 0.5mm x1 \varnothing 0.25mm x10
Operate temperature	-55°C ~ +70°C
Minimum bending radius	R15
Sensing distance/FZ1-N	30mm

PRD-420

Free cut

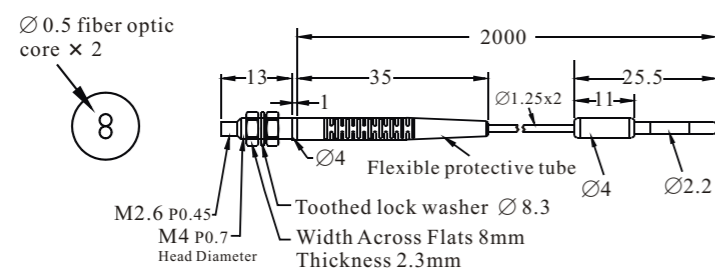

Fiber material	Plastic
Fiber Type	Precision
Fiber diameter	D \varnothing 1.25mm d \varnothing 0.5mm
Operate temperature	-55°C ~ +70°C
Minimum bending radius	R15
Sensing distance/FZ1-N	25mm

PRD-420-I

Free cut

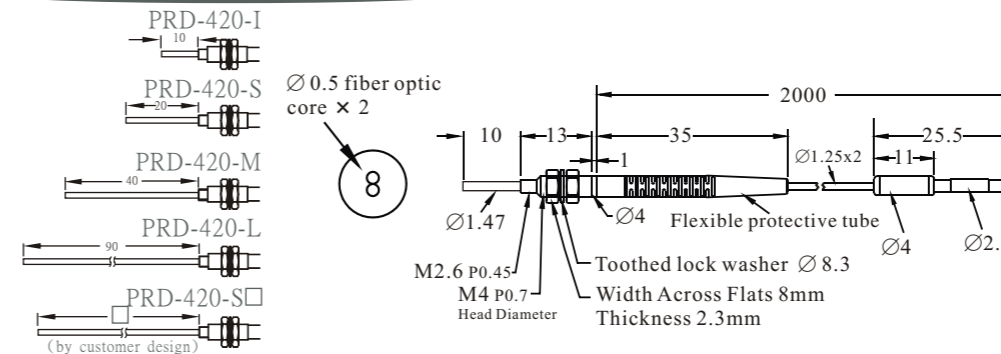

Fiber material	Plastic
Fiber Type	Precision
Fiber diameter	D \varnothing 1.25mm d \varnothing 0.5mm
Operate temperature	-55°C ~ +70°C
Minimum bending radius	R15
Sensing distance/FZ1-N	25mm

PRC-320

Free cut

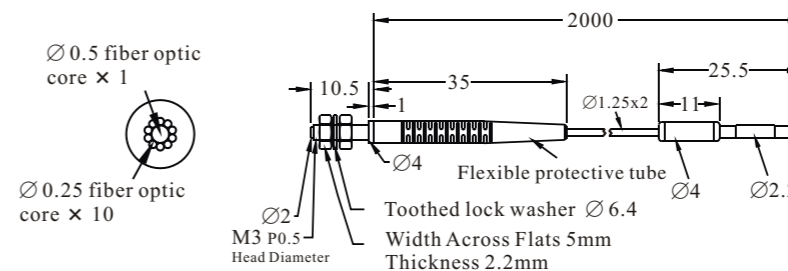

Fiber material	Plastic
Fiber Type	Coaxial
Fiber diameter	D \varnothing 1.25mm x1 \varnothing 1.25mm x1 d \varnothing 0.5mm x1 \varnothing 0.25mm x10
Operate temperature	-55°C ~ +70°C
Minimum bending radius	R15
Sensing distance/FZ1-N	30mm

PRD-320

Free cut

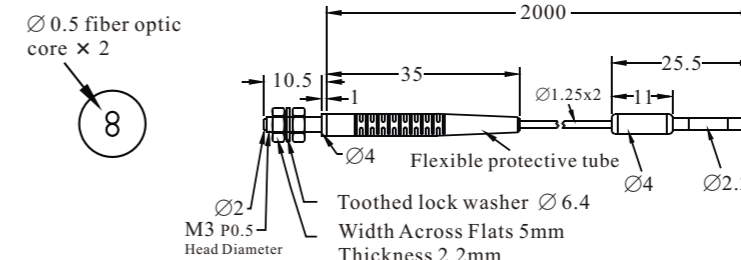

Fiber material	Plastic
Fiber Type	Precision
Fiber diameter	D \varnothing 1.25mm d \varnothing 0.5mm
Operate temperature	-55°C ~ +70°C
Minimum bending radius	R15
Sensing distance/FZ1-N	25mm

PRD-320-I

Free cut

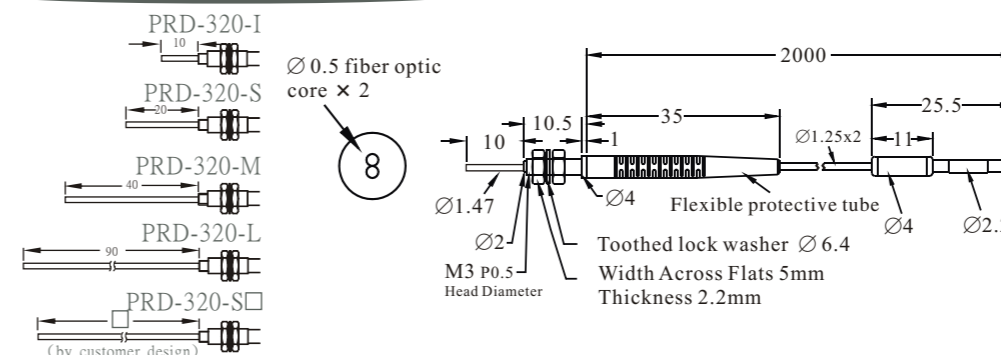

Fiber material	Plastic
Fiber Type	Precision
Fiber diameter	D \varnothing 1.25mm d \varnothing 0.5mm
Operate temperature	-55°C ~ +70°C
Minimum bending radius	R15
Sensing distance/FZ1-N	25mm